



Heartland Alliance  
Heartland Alliance International  
Heartland Alliance Health  
Heartland Housing  
Heartland Human Care Services

## **REQUEST FOR QUALIFICATIONS & PROPOSALS**

**RFQ/RFP# 5501.2019.3**

**Englewood Health Center Dental Expansion:  
Architectural Services**

**DEADLINE FOR SUBMITTING  
PROPOSAL July 12, 2019**

**ATTN: Bemnet Yigzaw  
Facilities Manager  
Heartland Alliance Health**

**TABLE OF CONTENTS**

**SECTION**

**I. Introduction**

- A. Introduction
- B. Background
- C. Contract Term / Term of Services

**II. Scope of Work**

- A. Work Requirements
- B. Any Other Items

**III. Proposer's Submittal**

Submittal Instructions

**IV. Key RFQ Information**

- A. Introduction
- B. RFQ Timeline
- C. Communication, Interpretation and Addenda

**V. Evaluation Criteria**

**VI. Diversity**

**VII. Conflict of Interest and Vendor Code of Conduct**

**VIII. Additional Information**

**IX. Terms and Conditions**

**X. Attachments and Exhibits**

Attachment A – Proposal Contact Information

Attachment B – Cost Proposal Sheet

Attachment C – Proposed Designs

**List of Exhibits**

Exhibit 1 – Insurance Requirements

**List of Appendix**

Appendix 1 – Certification of Independent Price Determination

Appendix 2 – Certification Regarding Debarment, Suspension, Proposed  
Debarment, and Other Responsibility Matters

Appendix 3 – Heartland Alliance Terms and Conditions

**I. INTRODUCTION**

**A. Introduction**

Heartland Alliance Health (HAH) is seeking Statement of Qualifications and cost proposals from qualified architects and architectural firms to provide architectural services at the Englewood Health Center located at 5501 S Halsted Street, Chicago, IL 60621.

The mission of Heartland Alliance Health is to provide holistic, comprehensive, accessible, affordable and quality primary and dental health care, programs with particular focus on the health care needs of the medically underserved population.

**B. Background**

The scope of this project includes converting existing rooms into 2 dental operatories with mechanical and sterilization station. This will allow provision of new dental services including: Emergency care, exam and full mouth x-rays, cleanings, fillings and extractions. HAH is looking for qualified architects with a self-certification credential to assist in attaining the building permit for this project. The total budget for this project is approximately \$264,000.00 including architectural/engineering, construction, furniture, equipment and other soft costs.

**C. Contract Term / Term of Services**

The term of this agreement resulting from this solicitation will be for one (1) year.

**II. SCOPE OF WORK**

The selected architect will be required to perform the scope of services outlined below, but not limited to:

1. Programming
  - a. Review floor plans of existing clinic and identify the best location for staff to perform dental services (see Attachment C).
  - b. Review requirements from dental equipment vendors to confirm space and layout requirements.
2. Concept/ Schematic Design
  - a. Tasks include, but are not limited to, code and ordinance review and analysis; permit review; preliminary schematic drawings; active participation in cost estimating process and life-cycle cost/benefit analysis led by a general contractor.

- b. Provide preliminary MEP/FP plans to assist the General Contractor in developing the construction budget.
  - c. If required, review the Schematic Design with local building code and public safety officials to determine additional requirement, if any.
3. Design Development/ Construction Documents/ Permitting
- a. Tasks include, but is not limited to, developing drawings and calculations as required to submit for applicable building permits; developing construction drawings, preparing site demolitions plans; providing floor plans, interior elevations as required, reflected ceiling plans as required, interior partition details, room finish schedule, door schedule, and casework elevations as required; coordinating and integrating structural, MEP, and fire protection systems with architectural design.
  - b. Coordinate design and Construction Documents with all Local, State, and Federal requirements for a building of this type.
  - c. Prepare, with input from the Owner, all permit application forms and submit with permit drawings to all appropriate agencies.
  - d. Modify permit documents and drawings and resubmit per comments provided by building code officials as required to secure all needed permits.
4. Construction Administration
- a. Construction administration phase services include, but are not limited to, reviewing material submittals and system shop drawings; conducting periodic site visits and providing construction oversight if required; issuance of the Certificate of Substantial Completion; and preparing and managing punch list items for incomplete work.
  - b. Respond to inquiries and provide reasonable documentation from lender and lenders' inspecting architects, if required.

### **III. PROPOSER'S SUBMITTAL**

Submittal Instructions:

Respondents must submit Statement of Qualifications and Cost proposal in separate sealed envelopes no later than the date and time specified on the cover of the RFP. Qualifications must include the following:

- 1. Cover/Transmittal Letter
  - A. Executive Summary – Provide an overview of the Proposer's company including the range of services offered by the Proposer, years in business, and a brief history
- 2. Experience and Qualification Statement
  - A. List of key personnel, qualifications and organizational chart. Qualifications of firm specifically at they relate to this project.
  - B. Firm experience on similar projects. Submit a list of minimum three (3) projects by your firm that best represents a similar scope and budget within the past three (3) years. For each project, include the following:
    - i. Project name and location
    - ii. Project owner name, address, phone number, email
    - iii. Brief description of project
    - iv. Budget
    - v. Completion date

**Heartland Alliance  
Heartland Alliance International  
Heartland Alliance Health  
Heartland Housing  
Heartland Human Care Services**

C. State your ability to begin work and the capacity of your firm to dedicate resources needed to provide the services requested

3. Describe your firm and its capabilities for the requested services

A. Number of years in business

B. Number of employees

C. Experience your firm has had within the past five (5) years providing similar services to organizations like Heartland Alliance

4. Operations Plan

Proposers shall prepare a detailed method of approach to the scope of work which indicates the services proposed to be performed by the firm. This section should confirm the firm understanding of the scope of work.

The firm should clearly outline the recommended approach of the organization in meeting the responsibilities that Heartland Alliance has outlined. The method of approach should be addressed in a manner that reflects an understanding and commitment to provide the requested services in a professional and timely manner. This approach must be submitted with the cost in a separate sealed envelope from the Statement of Qualifications..

5. Provide a minimum of three (3) client references with names, title, and contact information

6. Provide a job description for each proposed position

7. Proposer Contact Information Sheet (Attachment A)

8. Cost Proposal Sheet (Attachment B)

**I. Key RFP Information**

**A. Introduction**

Heartland Alliance Health will receive Statement of Qualifications and Cost Proposal at 4750 N Sheridan Road, Suite 473, Chicago, IL 60640, July 12<sup>th</sup>, 2019 by 5:00pmCT. Three (3) copies including one (1) clearly marked "original" shall be delivered to

Heartland Alliance Health  
Attn: Bemnet Yigzaw  
4750 N. Sheridan Road  
Suite 473  
Chicago, IL 60640

**Heartland Alliance  
Heartland Alliance International  
Heartland Alliance Health  
Heartland Housing  
Heartland Human Care Services**

Information submitted after the designated date and time will not be accepted.

**B. RFQ Timeline**

|                           |  |
|---------------------------|--|
| RFQ Issued                | <b><i>June 28<sup>th</sup>, 2019</i></b> |
| Respondents Questions Due | <b><i>July 5<sup>th</sup>, 2019</i></b>  |
| Answers to Questions      | <b><i>July 10<sup>th</sup>, 2019</i></b> |
| RFQ Due                   | <b><i>July 12, 2019</i></b>              |

Proposals submitted after the designated date and time will not be accepted for any reason and will be returned unopened to the originator.

**C. Communication, Interpretation and Addenda**

No respondent is entitled to rely upon any oral interpretation by Heartland Alliance or its representative concerning the meaning of this RFQ. This RFQ and any addenda will be available by contacting the designate person listed within this RFQ. It is the Respondent's obligation to obtain any addenda that may be subsequently issued.

All requests for interpretation must be made in writing and submitted no later than, ***July 5<sup>th</sup>, 2019***

Heartland Alliance may award one or more contracts based on the evaluation criteria contained within this RFQ to qualified firms.

**II. EVALUATION CRITERIA**

Heartland Alliance will review and evaluate qualifications in response to this RFQ. Heartland Alliance will use an Evaluation Committee to review and evaluate the qualifications and cost proposals. Throughout the evaluation and selection process, firms may be asked to furnish additional information, make oral presentations and attend meetings as requested by Heartland Alliance. Heartland Alliance will consider such criteria as Heartland Alliance deems and to be in the best interests of Heartland Alliance including but not limited to the following:

1. Firm qualifications, experience and knowledge
2. Technical ability and approach
3. Experience on similar projects
4. Professional references

Upon final selection based on qualifications, Heartland Alliance will review cost proposal and negotiate a fee. If a reasonable fee cannot be achieved with the respondent, negotiations will proceed with other qualified respondents until a mutually agreed scope and contract can be negotiated.

**III. DIVERSITY**

**Heartland Alliance  
Heartland Alliance International  
Heartland Alliance Health  
Heartland Housing  
Heartland Human Care Services**

Minority, Disadvantage, and Women-Owned Business Enterprises (MBE/DBE/WBEs) are encouraged to submit proposals. Heartland Alliance strives to provide opportunities to MBE/WBE/DBE's companies that has a diverse workforce and can supply products and services that will meet our business needs.

**IV. CONFLICT OF INTEREST AND VENDOR CODE OF CONDUCT**

Respondents must disclose of any past, present, or future relationships with any parties associated with the issuance, review, or management of this solicitation and anticipated award. Failure to provide this information may result in Heartland Alliance to remove respondent proposal from the selection process.

It is the responsibility of the respondent to become familiar with Heartland Alliance Vendor Code of Conduct <https://www.heartlandalliance.org/contracting-opportunities/> It is also a conflict of interest when a Heartland Alliance employee, officer or agent involved in the RFP process or contract has a financial or any other interest in the respondent. If a conflict of interest exist, the respondent cannot submit a proposal. Heartland Alliance in its sole discretion reserves the right to cancel the award if determines that any interested disclosed from any source gives the appearance of a conflict of interest.

**V. ADDITIONAL INFORMATION**

1. All costs incurred in the preparation and presentation of Proposals is the responsibility of each respondent. All supporting documentation and manuals with each Proposal will become the property of Heartland Alliance unless otherwise indicated by the Respondent at the time of submission.
2. Heartland Alliance reserves the right to reject any and all Proposals, to waive any informality, and to accept any proposals which may deem to be in the best interest of the organization.
3. Heartland Alliance may award one or more contracts based on the evaluation criteria contained within this RFP to responsible and responsive respondents, provided their proposals are in the best interest of Heartland Alliance.
4. Issuing this solicitation is not a guarantee that Heartland Alliance will award a purchase order/contract. Heartland Alliance has no contractual obligations with any vendor based upon the issuance of this solicitation.
5. Heartland Alliance may choose to award a purchase order / contract for part of the services within this solicitation.
6. Heartland Alliance may request from a short-listed of respondents additional written responses to a more specific and detailed scope of work that is based upon the general scope of work in the original stated solicitation.
7. Heartland Alliance reserves the right to accept or reject any or all proposals, issue

**Heartland Alliance  
Heartland Alliance International  
Heartland Alliance Health  
Heartland Housing  
Heartland Human Care Services**

addenda, or waive any formalities that are not to be material defects requiring rejection or disqualification or where such a waiver will promote increased competition. Any respondents may be excluded from further consideration for failure to fully comply with the requirements of this solicitation.

8. Heartland Alliance has the right to rescind this solicitation or rescind an award prior to the signing of a purchase order / contract due to any unforeseen changes in the direction of Heartland Alliance's client (U.S. Government), be it funding or programmatic.

**VI. TERMS AND CONDITIONS**

By submitting a proposal in response to this RFP, respondent agrees to accept Heartland Alliance Terms and Conditions (see Appendix 3)



**Heartland Alliance  
Heartland Alliance International  
Heartland Alliance Health  
Heartland Housing  
Heartland Human Care Services**

**Attachment (A)  
Business Contact Information**

Proposers must provide a business contact and alternate to address any RFP questions.

Name: \_\_\_\_\_

Title: \_\_\_\_\_

Phone: \_\_\_\_\_

Fax: \_\_\_\_\_

Address: \_\_\_\_\_

\_\_\_\_\_

Email: \_\_\_\_\_

**Alternate Business Contact**

Name: \_\_\_\_\_

Title: \_\_\_\_\_

Phone: \_\_\_\_\_

Fax: \_\_\_\_\_

Address: \_\_\_\_\_

\_\_\_\_\_

Email: \_\_\_\_\_

**Attachment (B)**  
**Cost Proposal Sheet**

Respondent must submit cost and the approach method in a Separate Sealed Envelope. This must include the description and cost information for each applicable category below.

**FEE PROPOSAL FORM**

**FIRM NAME:** [Insert Name ]

**PROJECT NAME:** Heartland Alliance Health Englewood Health Center Dental Expansion

| Phase                  | Fee in Dollars | Percent of Total Fee |
|------------------------|----------------|----------------------|
| Programming            |                | %                    |
| Schematic Design       |                | %                    |
| Design Development     |                | %                    |
| Construction Documents |                | %                    |
| Permitting             |                | %                    |
| Bidding                |                | %                    |
| Construction           |                | %                    |
| Close Out              |                | %                    |
| <b>Total</b>           |                | <b>100%</b>          |

Reimbursable Expenses

Signature Authorized Official:

Renderings

Title: \_\_\_\_\_

Printed Name: \_\_\_\_\_

**Attachment (C)  
Proposed Designs**

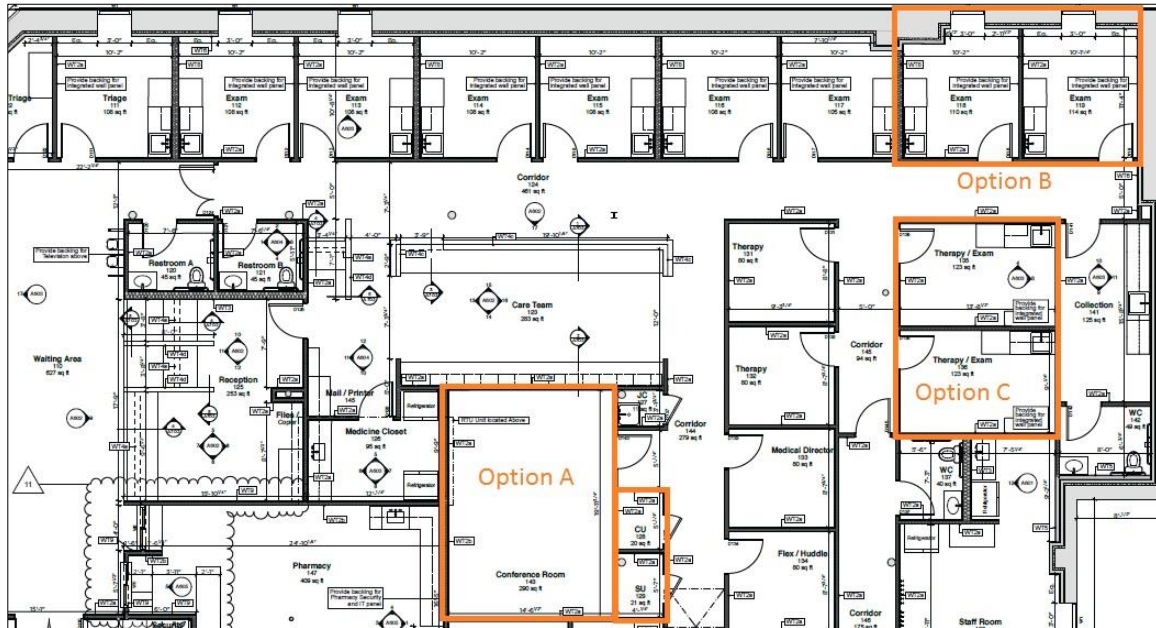

We have three locations within the health center to consider for the dental operatories. Two dental suppliers have provided their recommended location and layout (please see below specifications; one for Option A and one for Option B).



**Option A**  
Name: “Conference Room”, “CU” and “SU”  
Total Square Feet: 331 Sq Ft

**Option B**  
Name: “Exam 118” and “Exam 119”  
Total Square Feet: 224 Sq Ft  
\*If most ideal with “Exam 117”, please provide recommendation including Exam 117

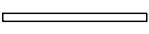
**Option C**  
Name: “Therapy/Exam 135” and “Therapy/Exam 136”  
Total Square Feet: 246 Sq Ft

|               |   |
|---------------|---|
| EXISTING WALL |   |
| NEW WALL      |  |

APPROVED \_\_\_\_\_

DATE \_\_\_\_\_

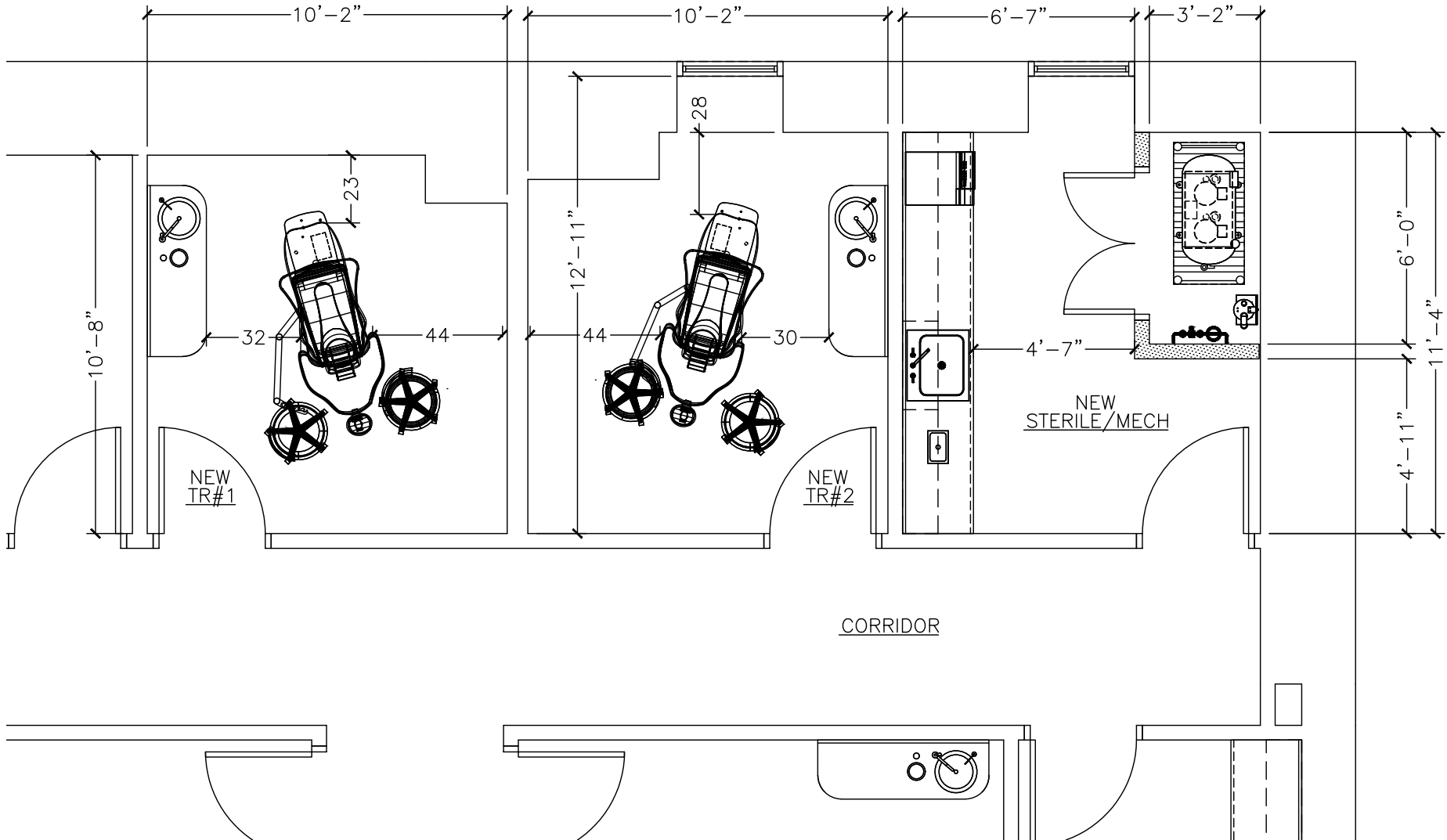

# Heartland Health Outreach

Chicago, Illinois

USABLE SQUARE FEET: 350

## DESIGN SCHEMATIC

|            |              |
|------------|--------------|
| PROJECT #  | DATE:        |
| MW18065-MW | 01/17/19     |
| DRAWN BY:  | REVIEWED BY: |
| MW         | ME           |

SCALE: N.T.S.





www.midmark.com  
design@midmark.com  
Phone: 1-800-MIDMARK

|  |                     |                            |                                   |                    |                         |               |  |
|--|---------------------|----------------------------|-----------------------------------|--------------------|-------------------------|---------------|--|
| Project Name: <b>Heartland Health Outreach</b> |                     | Project #: <b>DS190244</b> |                                   | Phase #: <b>01</b> |                         | Rev: <b>1</b> |  |
| Base Finish:                                   | 100-Undecided Solid | Tasklight:                 | Included                          | Top Material:      | Solid Surface           |               |  |
| Upper Finish:                                  | 100-Undecided Solid | Grommet:                   | AC22.0406, AC21.0406,             | Top Color:         | Undecided Solid Surface |               |  |
| Panel Style:                                   | Cove Panel          | Cutout:                    | None                              | Note:              |                         |               |  |
| Handle:  | None                | Note:                      |                                   | Sink:              | USX-1620-A              |               |  |
| Lock:  | No Lock             | Note:                      | <b>Field Measurement Required</b> | Faucet:            | CFT-8CHGSPULL-1         |               |  |

**Signed Drawings Required To Process Order**

(Signature) (Date)

See Cover Page For Terms and Conditions

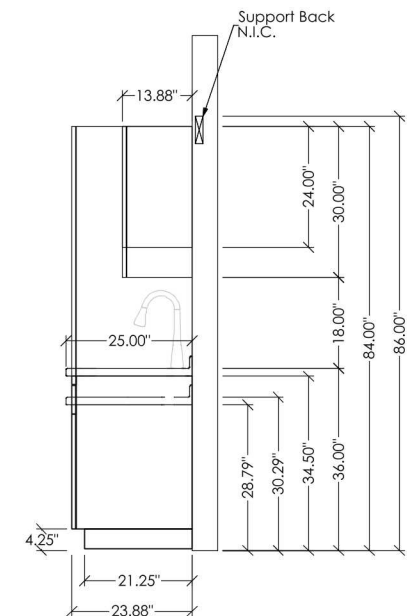
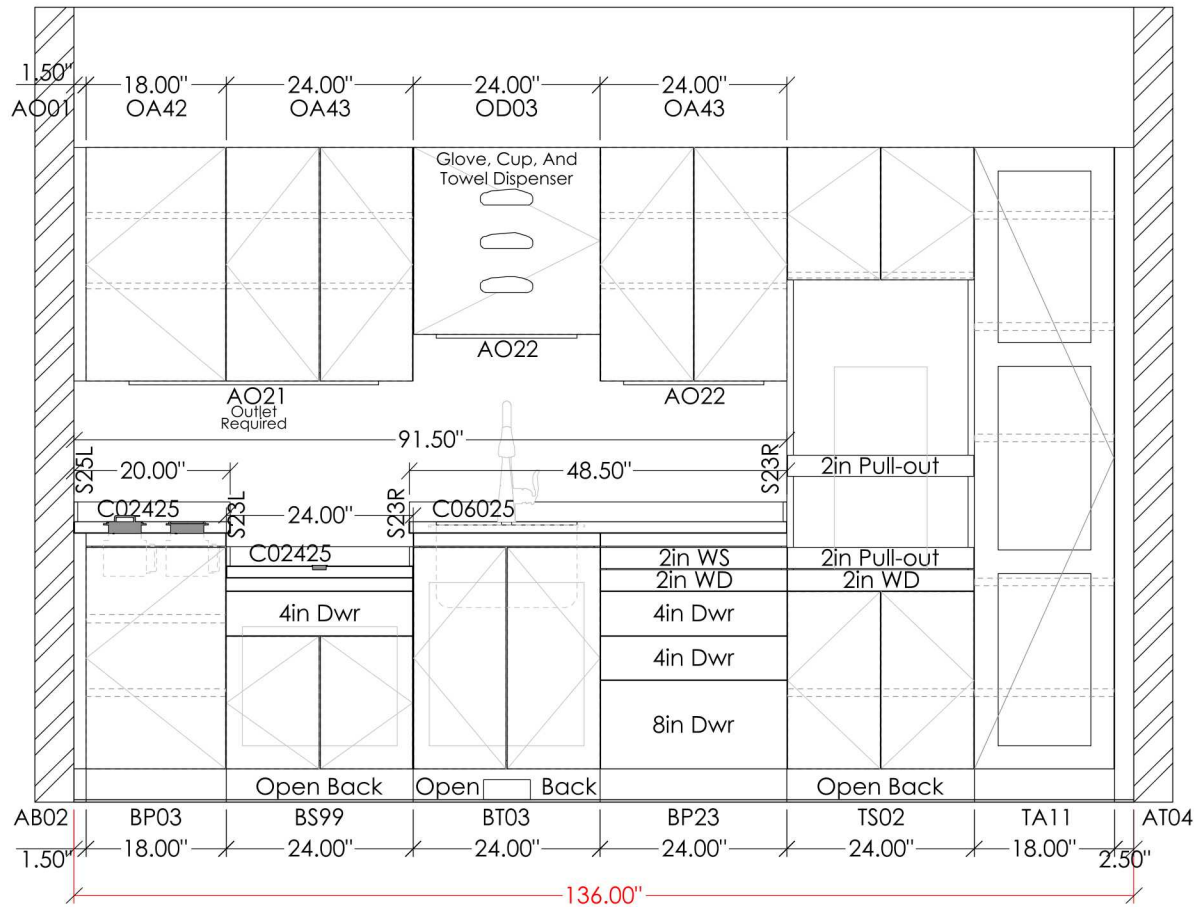



# Countertop Detail Sheet

## Solid Surface Detail C Integrated Backsplash 0.5" x 2.5"

### Design Considerations:

- \* 19", 25, & 31" tops available.
- \* Solid surface tops that exceed 144" or form an "L" shape will be sent as multiple pieces and require field seaming by a licensed solid surface installer.
- \* Integrated sinks and chutes will be attached.
- \* Midmark will only provide the sink and faucet cut outs if sink and faucet are purchased from Midmark.
- \* Solid surface tops will be manufactured based on the field measurements provided at the time of order.
- \* Contingent on design, side splash depth next to tall towers and drop down Ultra Sonic areas will be shorter than top.
- \* Standard countertop overhang for base cabinets is 1/2".
- \* Dental undermount sinks will be attached.

**Material:** 1/2" thick solid surface, 1-1/2" thick top with 1" thick, by 2.5" tall integrated backsplash, total height 4".

**Brands:** DuPont Corian

**Colors:** See color guide for standard color options; for non standard color options please call to confirm availability and extended leaded time.

### Features & Benefits:

- \* 3/8" radius front edge profile.
- \* Outside corners of solid surface tops will have a 3/4" radius.
- \* Loose set on side splash available, contoured to fit profile, 1/2" thick with waterfall front.
- \* Integrated solid surface sink for Medical or Animal Health will be Cameo White; Dental sinks will be Glacier White.
- \* 1" thick set on backsplash.

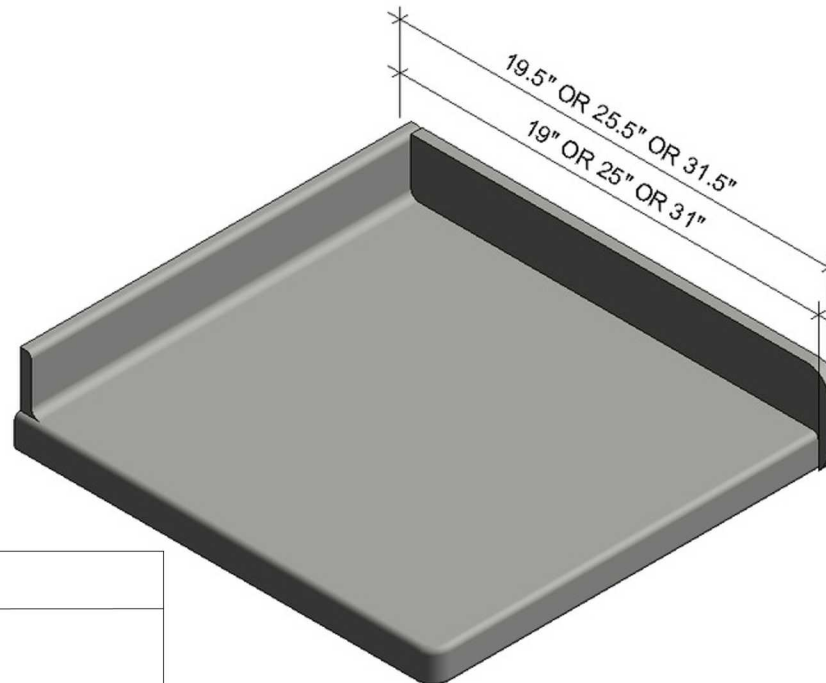

### Detail Drawings with Exact Dimensions

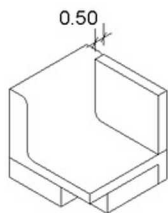

Sidesplash Detail

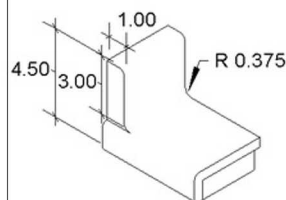

Backsplash Detail

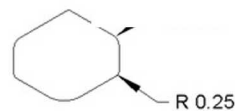

Front Edge Detail





www.midmark.com  
drawings-casework@midmark.com  
Phone: 1-800-MIDMARK

Project Name: **Heartland Health Outreach**

Project #: **DS190244**

Phase #: **01**

Rev: **1**

## Plumbing and Electrical Specs.

**Note: All local, state, and federal electrical & plumbing codes are to be followed when installing.**

This drawing is the sole property of Midmark Corporation and is to be used for illustration only. Actual product appearance may vary.

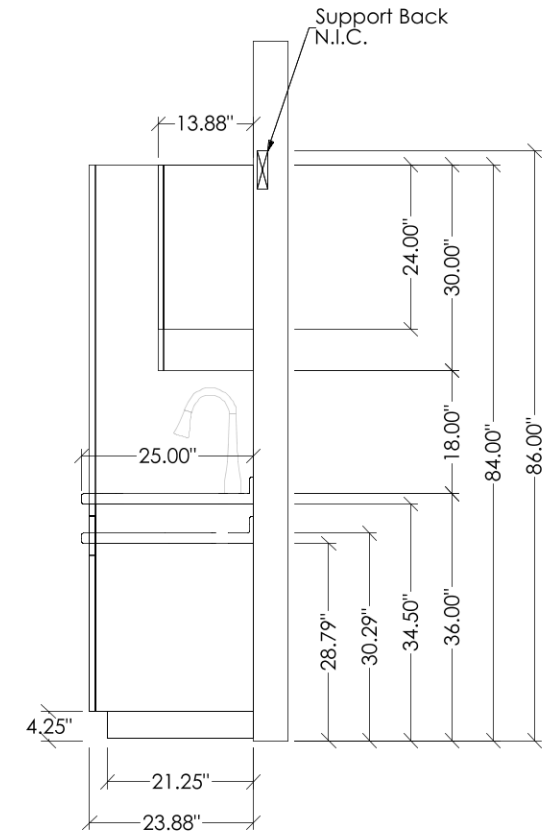
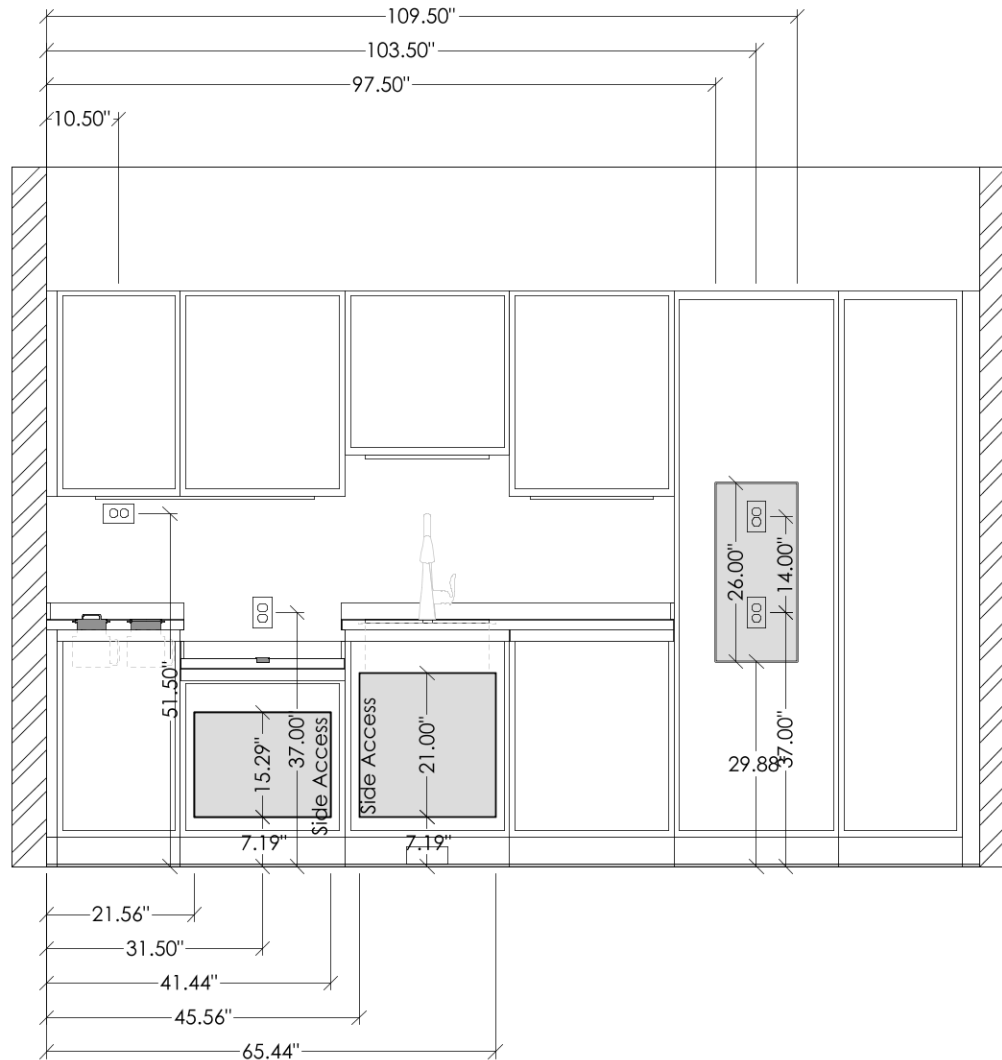





# PROPOSED FLOOR PLAN

**Heartland Dental Center**  
 5501 S. HALSTED ST.  
 Chicago IL

**JOB # 00252**

REVISION: 1 DATE: \_\_\_\_\_

SHEET # \_\_\_\_\_

DATE: \_\_\_\_\_

SCALE: 1/4" = 1' - 0"

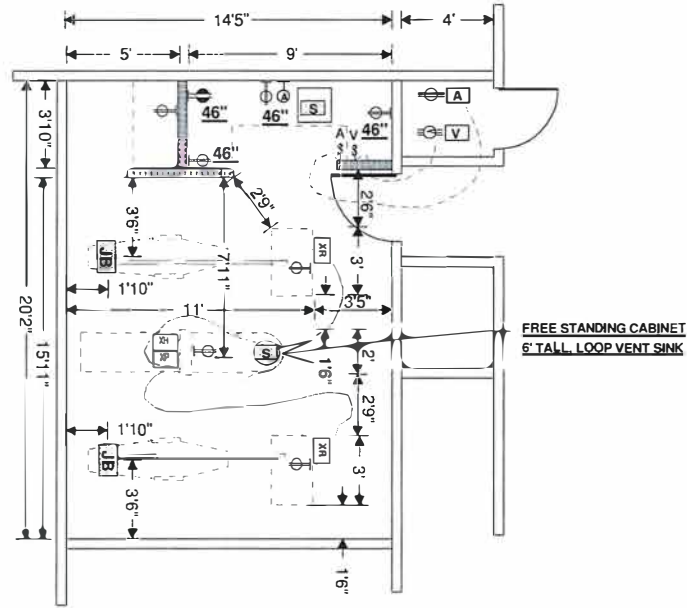
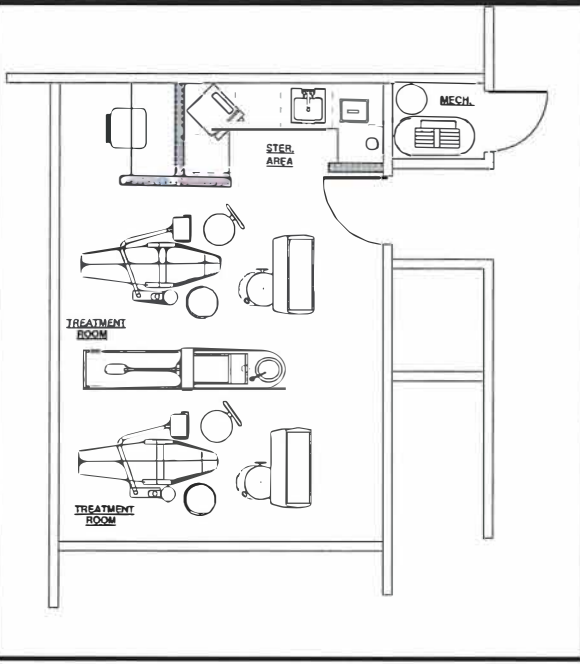

## PLUMBING SPECIFICATIONS

- V** VACUUM PUMP : PLUMBER SHALL PROVIDE 1 1/2" WASTE LINE, 12" ABOVE FLOOR. ALSO RUN 1 1/2" PVC VACUUM LINE FROM PUMP TO ALL POINTS REQUIRING VACUUM D.U., J.B. AND W.J.B. VACUUM LINES MUST BE PITCHED TO VACUUM PUMP SIMILAR TO WASTE LINE. PLUMBER SHALL MAKE ALL FINAL CONNECTION TO ALL COMPONENT PARTS OF THIS SYSTEM. SEE MFG. SPECS FOR FULL DETAILS OF INSTALLATION OF SYSTEM. (PLUMBER TO VENT TO OUTSIDE OF BLDG.)
- A** AIR COMPRESSOR : REQUIRES PLUMBER TO RUN 1/2" COPPER TUBING FROM 24" AFF AT COMPRESSOR LOCATION TO ALL POINTS MARKED JB, DU, WJB, & A. ALL FITTINGS INSTALLED ON AIR LINES TO BE BRASS ON COPPER ONLY. AT COMPRESSOR LOCATION TERMINATE LINE 1/2" FEMALE ADAPTER. PLUMBER MUST PRESSURE TEST AIR LINES AT 150 PSI FOR 24 HRS. WITH NO LEAKS. FINAL CONNECTION BY PLUMBER.
- S** SINK : PLUMBER SHALL PROVIDE WASTE LINE 1" AFF AND HOT AND COLD WATER WITH SHUT OFF VALVES 2" ABOVE AND WITH IN 4" OF WASTE LINE. DOCTOR WILL SUPPLY SINK AND FAUCET. PLUMBER TO MAKE ALL FINAL CONNECTION & SUPPLY THE "P" TRAP AND TAIL PIECE FOR EACH SINK.
- A** AIR VALVE : PLUMBER SHALL INSTALL AND HOOK-UP VALVE SUPPLIED BY DOCTOR TO 1/2" MALE PIPE 1" OUT FROM FINISHED WALL VALVE TO BE RIGIDLY SECURED TO FINISHED WALL BY PLUMBER.
- JB** DENTAL UNIT REQUIRES: 1/2" AIR LINE 1/2" VACUUM LINE. SEE MFG. SPECS. PLUMBER SHALL POSITION TEMPLATE FOR JB & RUN AIR, AND VACUUM TO DESIGNATED TEMPLATE LOCATION AS SHOWN ON FLOOR PLAN. SEE TEMPLATES FOR DETAILS OF SIZE AND HEIGHT OF FITTINGS. PLUMBER TO SUPPLY AND INSTALL 3/8" COMPRESSOR VALVES ON ALL AIR LOCATIONS.

## ELECTRICAL SPECIFICATIONS

- A** AIR COMPRESSOR REQUIRES: ELECTRICIAN AND RUN 220 VOLT 30 AMP SERVICE FOR THE VACUUM PUMP ROUGH IN 30" AFF. SEE MFG. SPECS FOR FULL DETAILS. CONNECT TO REMOTE SWITCH WITH PILOT LIGHT. SEE FLOOR PLAN FOR LOCATION.
- V** VACUUM PUMP REQUIRES: ELECTRICIAN RUN 220 VOLT 20 AMP SERVICE FOR THE VACUUM PUMP ROUGH IN 30" AFF. SEE MFG. SPECS FOR FULL DETAILS. CONNECT TO REMOTE SWITCH W/ PILOT LIGHT. SEE FLOOR PLAN FOR LOCATION.
- W** WALL OUTLET : 115V OUTLET SEE PLAN FOR HEIGHT OF OUTLET. IF NOT SPECIFIED ON PLAN THE HEIGHT IS 12" A.F.F.
- W** WALL RECEPTICAL FOR STERILIZER : 115 VOLTS 20 AMPS SEPERATE CIRCUIT SEE FLOOR PLAN FOR HEIGHT.
- NOTE:**  
SEE COMPUTER SUPPLIER FOR ELECTRICAL REQ. FOR COMPUTER SYSTEM
- JB** JUNCTION BOX : REQUIRES ELECTRICIAN TO RUN 115 VOLTS 20 AMPS TO EACH UNIT AND SUPPLY A QUAD OUTLET. SEE DENTAL REP. FOR LOCATIONS AND TEMPLATE. FINAL CONNECTION BY ELECTRICIAN.
- XR** X-RAY REMOTE 60" AFF
- XP** 42" AFF
- XH** X-RAY ARM AND HEAD 42" AFF  
ELECTRICIAN SHALL PROVIDE AND RUN 2 # 18 STRANDED WIRES FROM XH 42" AFF TO THE XR 60" AFF. DIMENSIONS ARE TO THE CENTER OF BOX. RUN FLEXIBLE, MULTICOLOR STRANDED WIRE LEAVING 3 FT. OF WIRE AT EACH LOCATION.

**Heartland Dental Center**  
5501 S. HALSTED ST.  
Chicago IL

JOB # 00252

REVISION: 1 DATE: \_\_\_\_\_

SHEET #

DATE:

SCALE: 1/4" = 1' - 0"

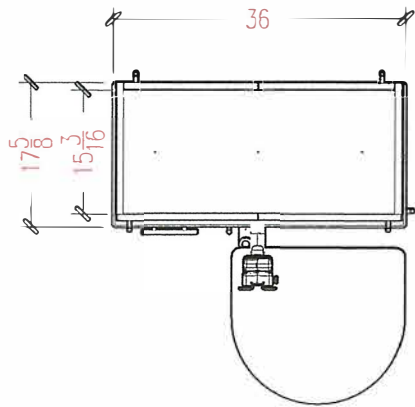

**153659-003**  
**Work Surface Options**  
**Assistant Instrument Options**

Support: None  
 Top: (Standard) - Corian top

|                        |  |  |
|------------------------|--|--|
| BASE / TOE KICK TYPE   | STAINLESS STEEL BASE   |  |
| COUNTERTOP COLOR       | STANDARD COLOR (CORIAN) (GROMMET T.B.D.)   |  |
| RESIN                  | N/A  |  |
| CABINET UPHOLSTERY     | STANDARD COLOR   |  |
| UPPER CABINET LAMINATE | COLOR: DEALER TO SPECIFY<br>1/2 MIL: MATCHING BANDING<br>3 MIL: MATCHING BANDING | STANDARD COLOR<br>T-MOLDING: SC<br>GROMMET: SC |
| LOWER CABINET LAMINATE | COLOR: DEALER TO SPECIFY<br>1/2 MIL: MATCHING BANDING<br>3 MIL: MATCHING BANDING | STANDARD COLOR<br>T-MOLDING: SC<br>GROMMET: SC |

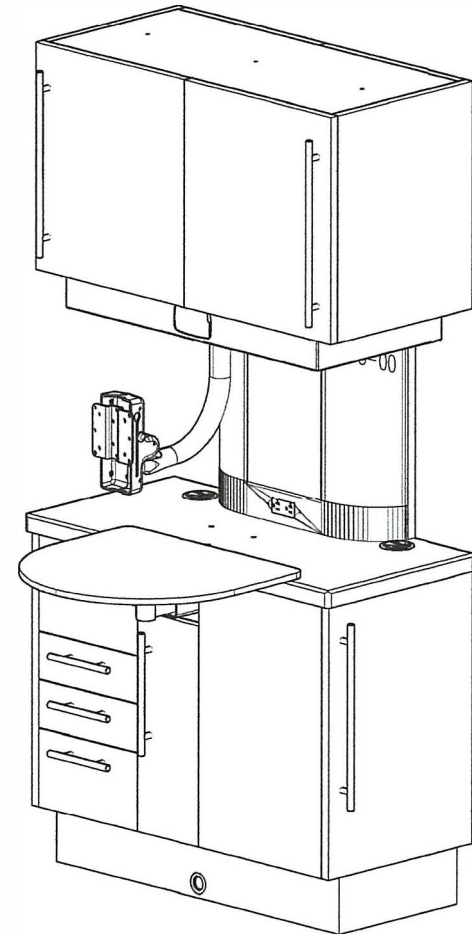
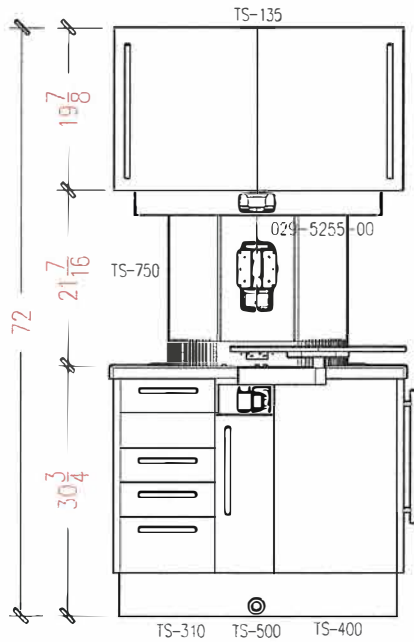

CABINET DESCRIPTION: TS3690 TREATMENT STATION

DRAWING NUMBER: DA182776 A-1 4/29/19 AF

PROJECT NAME: HEARTLAND CHC SOUTH

The drawings/information included herein is confidential and property of Midmark Corporation. Any use of these documents without written consent from Midmark Corporation is strictly prohibited.

SIGNED DRAWING IS REQUIRED TO PROCESS ORDER

CUSTOMER APPROVAL \_\_\_\_\_

DATE \_\_\_\_\_

I have done field measurements or will have the walls built to match the overall length on the drawings. (Any changes to the length must be noted on the sign-offs.)

**Terms N.I.C. (Not In Contract):**

1. Reagent walls, chases
2. Installation and/or de-installation
3. Plumbing hook-up
4. COUNTERTOP CUTOUTS
5. Electrical wiring or hook-up
6. Taxes
7. Project Management
8. Special shipping arrangements
9. Trash Removal



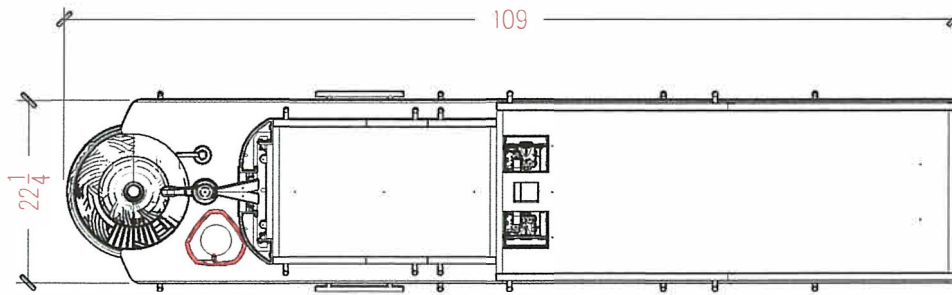

|                        |  |  |
|------------------------|--|--|
| SINK BOWL TYPE         | STAINLESS STEEL UNDERMOUNT   |  |
| FAUCET TYPE            | TOUCH / PROXIMITY FAUCET WITH SOAP   |  |
| BASE / TOE KICK TYPE   | STAINLESS STEEL BASE   |  |
| COUNTER TOP COLOR      | STANDARD COLOR (CORIAN) (GROMMET T.B.D.)   |  |
| CABINET UPHOLSTERY     | STANDARD COLOR   |  |
| UPPER CABINET LAMINATE | COLOR: DEALER TO SPECIFY<br>1/2 MIL: MATCHING BANDING<br>3 MIL: MATCHING BANDING | STANDARD COLOR<br>T-MOLDING: SC<br>GROMMET: SC |
| LOWER CABINET LAMINATE | COLOR: DEALER TO SPECIFY<br>1/2 MIL: MATCHING BANDING<br>3 MIL: MATCHING BANDING | STANDARD COLOR<br>T-MOLDING: SC<br>GROMMET: SC |

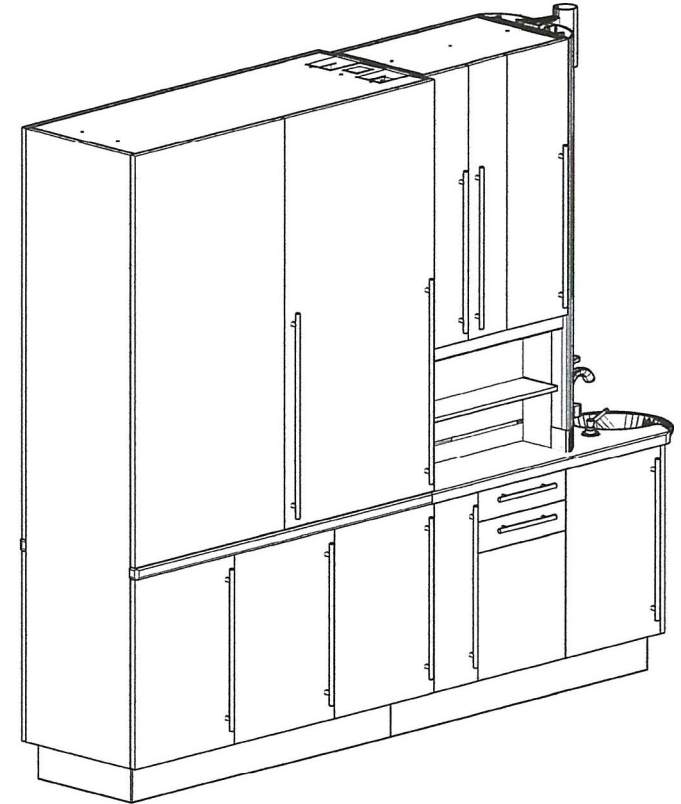
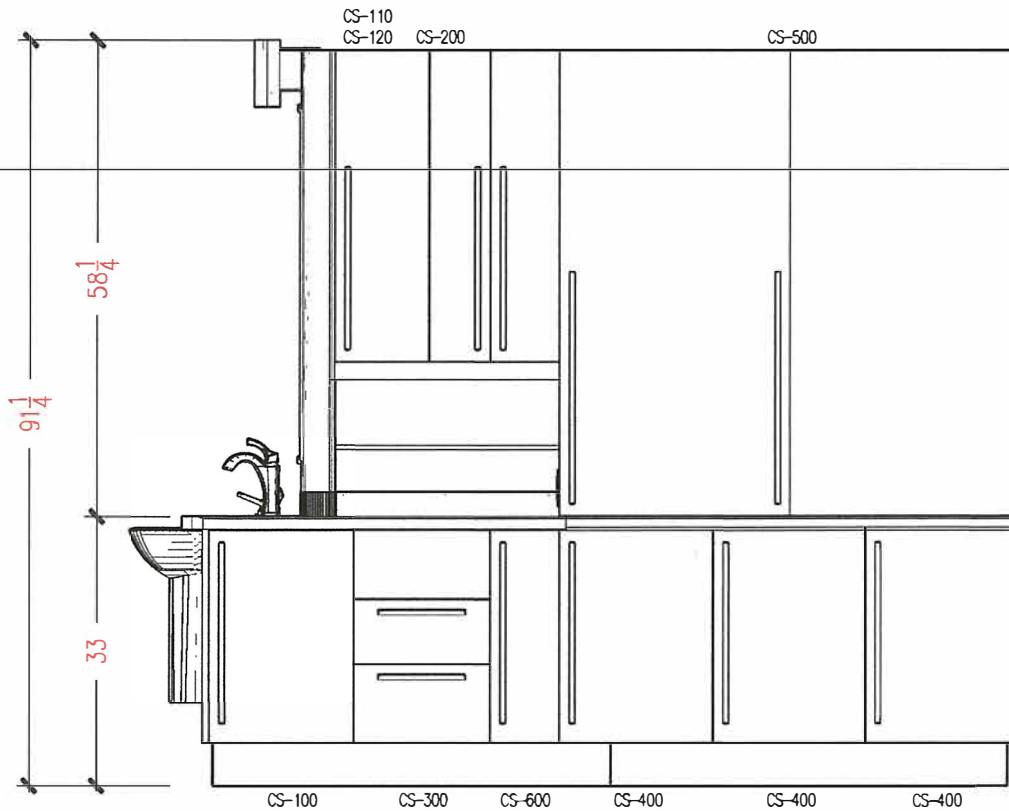

CABINET DESCRIPTION: CS109-TB CENTRAL STATION  
 DRAWING NUMBER: DA182776 B-1 2/29/19 AF  
 PROJECT NAME: HEARTLAND CHC SOUTH

The drawings/Information Included herein Is Confidential and Property of Midmark Corporation. Any use of these Documents without Written Consent from Midmark Corporation is Strictly Prohibited.

SIGNED DRAWING IS REQUIRED TO PROCESS ORDER

CUSTOMER APPROVAL \_\_\_\_\_ DATE \_\_\_\_\_

I have done field measurements or will have the walls built to match the overall length on the drawings.  
 (Any changes to the length must be noted on the sign-offs.)

- Terms N.I.C. (Not In Contract):**
1. Reagent walls, chases
  2. Installation and/or de-Installation
  3. Plumbing hook-up
  4. **COUNTERTOP CUTOUTS**
  5. Electrical wiring or hook-up
  6. Taxes
  7. Project Management
  8. Special shipping arrangements
  9. Trash Removal





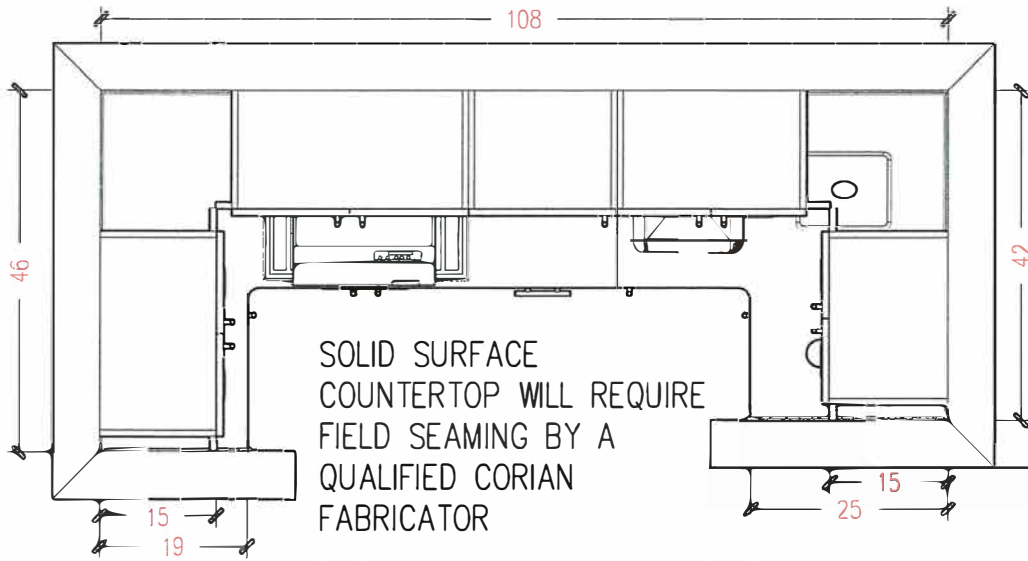

|                        |   |   |
|------------------------|---|---|
| SINK BOWL TYPE         | N/A   |   |
| FAUCET TYPE            | N/A   |   |
| BASE / TOE KICK TYPE   | STAINLESS LAMINATED TOE KICK  |   |
| HANDLE TYPE            | BAR PULL  |   |
| COUNTER TOP COLOR      | STANDARD COLOR (CORIAN) (GROMMET T.B.D.)                                    |   |
| UPPER CABINET LAMINATE | COLOR: DEALER TO SPECIFY<br>.5MM: MATCHING BANDING<br>3MM: MATCHING BANDING | STANDARD COLOR<br>GROMMET: SC<br>T-MOLD: SC |
| LOWER CABINET LAMINATE | COLOR: DEALER TO SPECIFY<br>.5MM: MATCHING BANDING<br>3MM: MATCHING BANDING | STANDARD COLOR<br>GROMMET: SC<br>T-MOLD: SC |

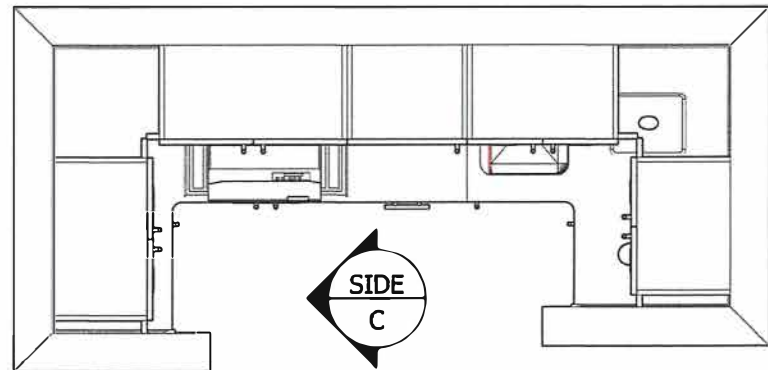
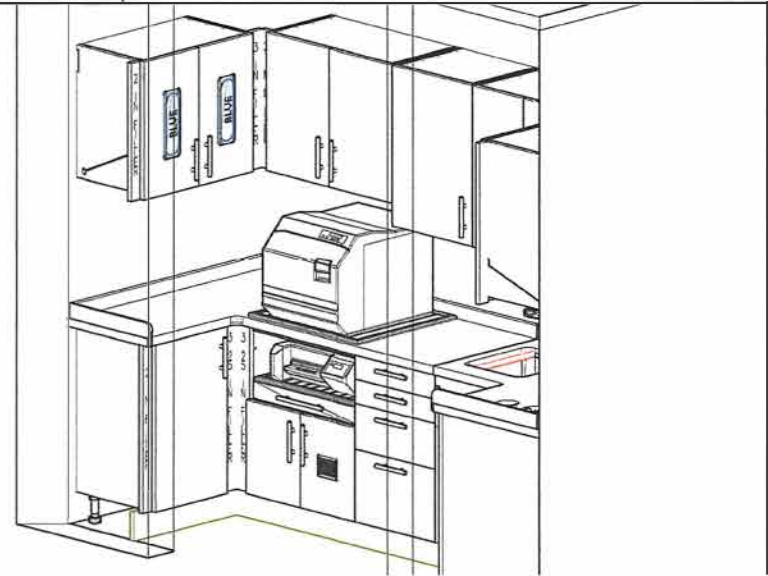
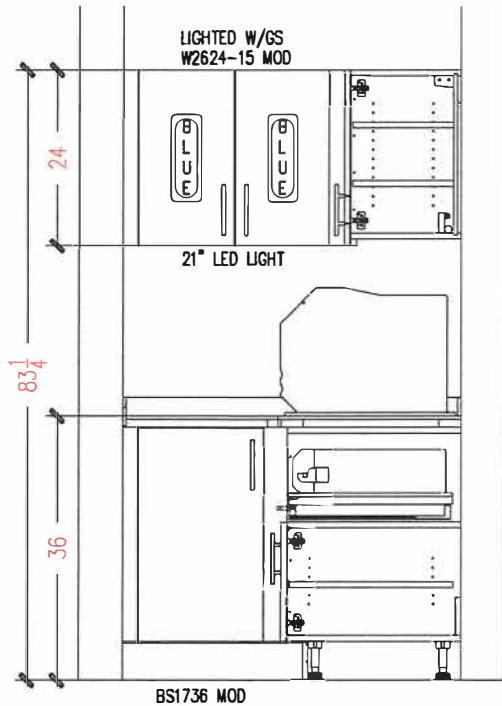

CABINET DESCRIPTION: MODULAR STERILE SIDE C  
DRAWING NUMBER: DA18 2776 C-1 4/29/19 AF  
PROJECT NAME: HEARTLAND CHC SOUTH

The drawings/information included herein is Confidential and Property of Midmark Corporation. Any use of these Documents without Written Consent from Midmark Corporation is Strictly Prohibited.

SIGNED DRAWING IS REQUIRED TO PROCESS ORDER

CUSTOMER APPROVAL \_\_\_\_\_ DATE \_\_\_\_\_

I have done field measurements or will have the walls built to match the overall length on the drawings. (Any changes to the length must be noted on the sign-offs.)

- Terms N.I.C. (Not In Contract):**
1. Reagent walls, chases
  2. Installation and/or de-installation
  3. Plumbing hook-up
  4. COUNTERTOP CUTOUTS
  5. Electrical wiring or hook-up
  6. Taxes
  7. Project Management
  8. Special shipping arrangements
  9. Trash Removal

**midmark**  
ARTIZAN EXPRESSIONS®

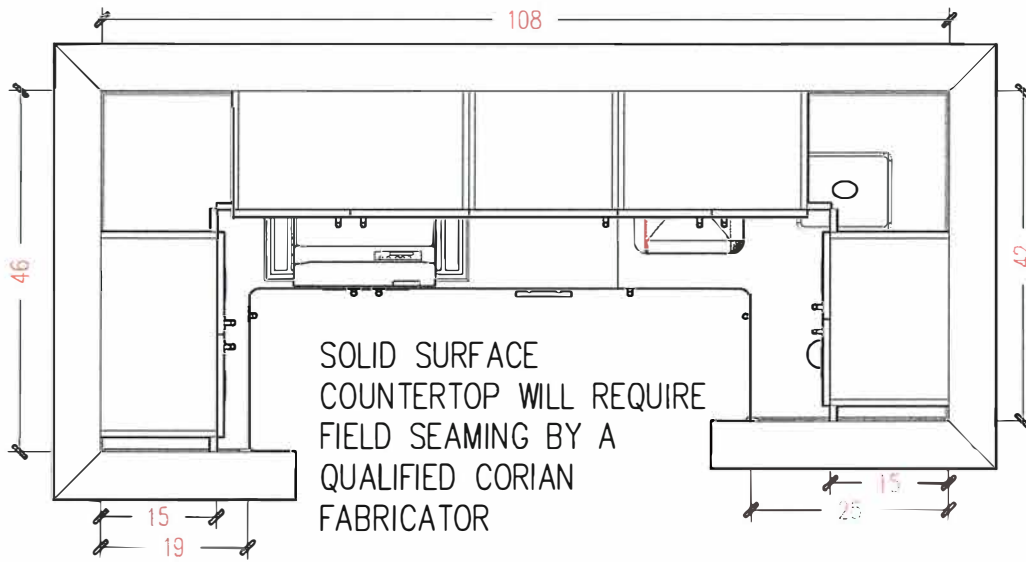

|                        |   |                           |
|------------------------|---|---------------------------|
| SINK BOWL TYPE         | STAINLESS STEEL UNDERMOUNT  |                           |
| FAUCET TYPE            | CHROME FAUCET W/ SOAP & TAPMASTER   |                           |
| BASE / TOE KICK TYPE   | STAINLESS LAMINATED TOE KICK  |                           |
| HANDLE TYPE            | BAR PULL  |                           |
| COUNTER TOP COLOR      | STANDARD COLOR (CORIAN) (GROMMET T.B.D.)                                    |                           |
| UPPER CABINET LAMINATE | STANDARD COLOR  | STANDARD COLOR            |
|                        | COLOR: DEALER TO SPECIFY<br>.5MM: MATCHING BANDING<br>3MM: MATCHING BANDING | GROMMET: SC<br>T-MOLD: SC |
| LOWER CABINET LAMINATE | STANDARD COLOR  | STANDARD COLOR            |
|                        | COLOR: DEALER TO SPECIFY<br>.5MM: MATCHING BANDING<br>3MM: MATCHING BANDING | GROMMET: SC<br>T-MOLD: SC |

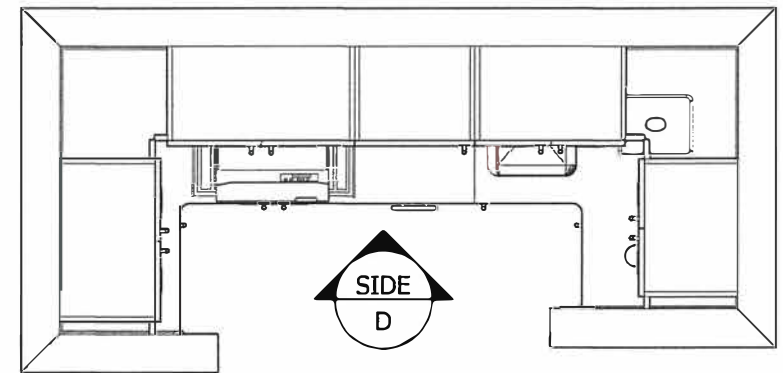
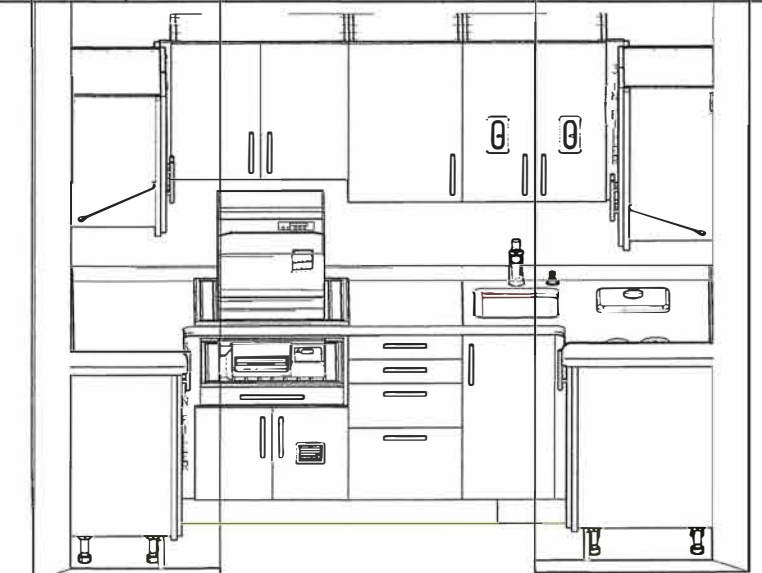
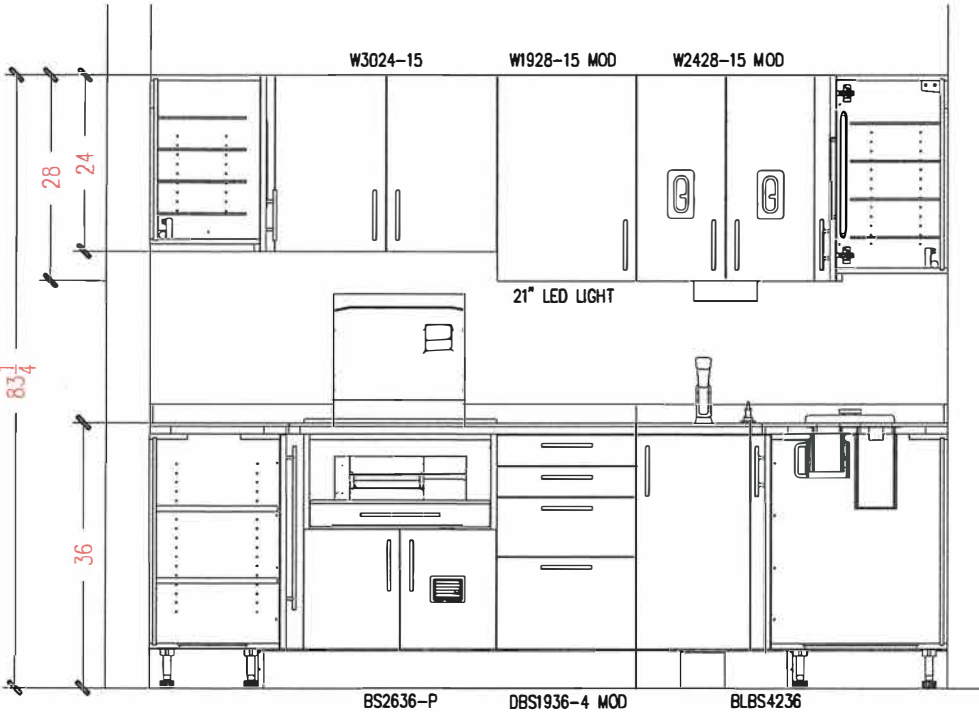

CABINET DESCRIPTION: MODULAR STERILE SIDE D  
 DRAWING NUMBER: DA182776 D-1 4/29/19 AF  
 PROJECT NAME: HEARTLAND CHC SOUTH

The drawings/Information included herein is Confidential and Property of Midmark Corporation. Any use of these Documents without Written Consent from Midmark Corporation is Strictly Prohibited.

SIGNED DRAWING IS REQUIRED TO PROCESS ORDER

CUSTOMER APPROVAL \_\_\_\_\_ DATE \_\_\_\_\_

I have done field measurements or will have the walls built to match the overall length on the drawings. (Any changes to the length must be noted on the sign-offs.)

- Terms N.I.C. (Not in Contract):**
1. Reagent walls, chases
  2. Installation and/or de-Installation
  3. Plumbing hook-up
  4. **COUNTERTOP CUTOUTS**
  5. Electrical wiring or hook-up
  6. Taxes
  7. Project Management
  8. Special shipping arrangements
  9. Trash Removal



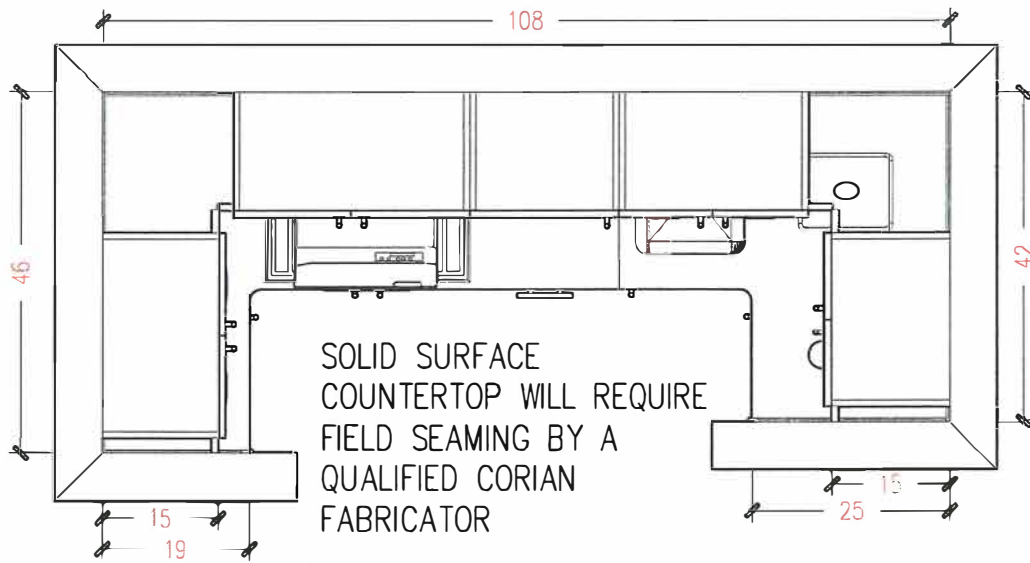

SOLID SURFACE  
COUNTERTOP WILL REQUIRE  
FIELD SEAMING BY A  
QUALIFIED CORIAN  
FABRICATOR

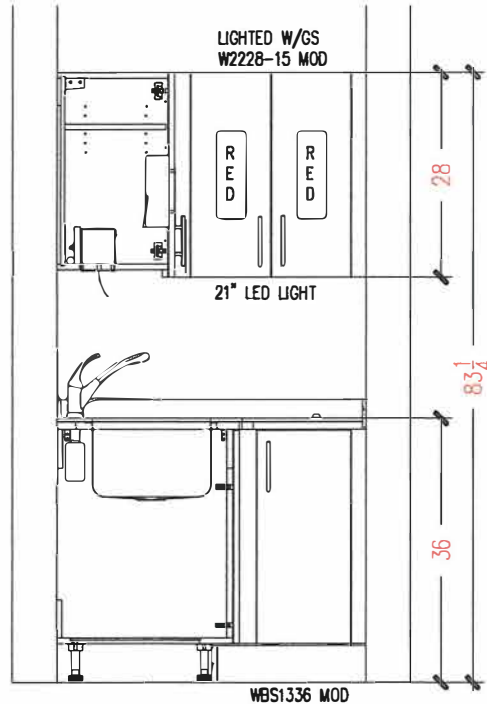

|                           |   |   |
|---------------------------|---|---|
| SINK BOWL TYPE            | N/A   |   |
| FAUCET TYPE               | N/A   |   |
| BASE / TOE KICK TYPE      | STAINLESS LAMINATED TOE KICK  |   |
| HANDLE TYPE               | BAR PULL  |   |
| COUNTER TOP COLOR         | STANDARD COLOR (CORIAN) (GROMMET T.B.D.)                                    |   |
| UPPER<br>CABINET LAMINATE | COLOR: DEALER TO SPECIFY<br>.5MM: MATCHING BANDING<br>3MM: MATCHING BANDING | STANDARD COLOR<br>GROMMET: SC<br>T-MOLD: SC |
| LOWER<br>CABINET LAMINATE | COLOR: DEALER TO SPECIFY<br>.5MM: MATCHING BANDING<br>3MM: MATCHING BANDING | STANDARD COLOR<br>GROMMET: SC<br>T-MOLD: SC |

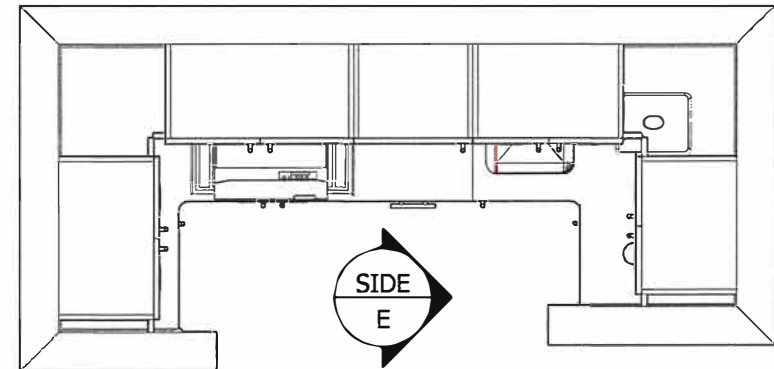
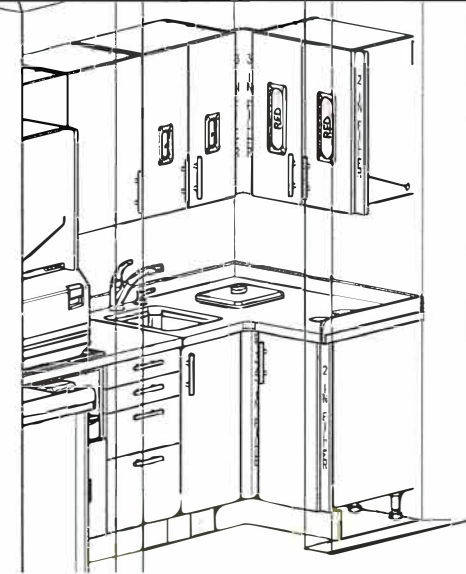

CABINET DESCRIPTION: MODULAR STERILE SIDE E

DRAWING NUMBER: DA182776 E

PROJECT NAME: HEARTLAND CHC SOUTH

The drawings/information included herein is Confidential and Property of Midmark Corporation. Any use of these Documents without Written Consent from Midmark Corporation is Strictly Prohibited.

SIGNED DRAWING IS REQUIRED TO PROCESS ORDER

CUSTOMER APPROVAL \_\_\_\_\_

DATE \_\_\_\_\_

I have done field measurements or will have the walls built to match the overall length on the drawings.  
(Any changes to the length must be noted on the sign-offs.)

Terms N.I.C. (Not In Contract):

1. Reagent walls, chases
2. Installation and/or de-Installation
3. Plumbing hook-up
4. COUNTERTOP CUTOUTS
5. Electrical wiring or hook-up
6. Taxes
7. Project Management
8. Special shipping arrangements
9. Trash Removal

midmark

ARTIZAN EXPRESSIONS

## **EXHIBIT 1 – INSURANCE REQUIREMENTS FOR VENDORS**

The following minimum insurance requirements apply to vendors. If the service or work represents an unusual or high risk, such as construction, additional insurance may be required. For more information, consult with the Enterprise Risk Management department by emailing [erm@heartlandalliance.org](mailto:erm@heartlandalliance.org)

### **Certificates of Insurance and Additional Insured**

All Vendors shall furnish Heartland Alliance with an original Certificate of Insurance listing "Heartland Alliance, 208 S. La Salle, Suite 1300 Chicago, IL 60604" as the certificate holder.

The Commercial General Liability and Auto Liability shall name Heartland Alliance, all subsidiaries and related entities, employees, officers, board of directors, agents and volunteers as additional insured by way of endorsement. Vendor shall require the same additional insured endorsements from Subcontractors.

### **Coverage and Policy Limits**

All insurance policies maintained by vendor must be issued by a company or companies rated at least "A" in A.M. Best's Key rating guide.

The vendor shall provide a 30-day notice of cancellation or non-renewal of coverage to Heartland Alliance. Such insurance must be primary as to any other valid and collectible insurance.

**Commercial General Liability:** *(required where vendor is not considered an independent contractor):*

- Each occurrence \$1,000,000
- General aggregate \$2,000,000 for bodily injury, personal injury and property damage liability.
- Coverage shall include all premises and operations, products/completed operations, separation of insureds, and contractual liability.

**Automobile Liability:** *(required if contracting party will be utilizing vehicles to perform/provide services on Heartland premise):*

- Combined single limit \$1,000,000 for bodily injury and property damage, including owned, hired and non-owned vehicle coverage.

**Umbrella/Excess Liability:** *(required where vendor is not considered an independent contractor):*

- Not less than \$2,000,000 per occurrence and in the aggregate.

**Workers' Compensation:** *(as required by applicable law or regulation):*

- Statutory limits

**Employers Liability:** *(as required by applicable law or regulation):*

- \$500,000 per each accident or illness



**Heartland Alliance  
Heartland Alliance International  
Heartland Alliance Health  
Heartland Housing  
Heartland Human Care Services**

**Other insurance that may be required**

**Professional Liability:** *(required by independent contractors)*: If vendor is engaged for professional services by a professional on staff or under a consulting agreement, vendor must secure, acquire and maintain, or require its independent consultant or Subcontractor to acquire and maintain, Professional Liability insurance in limits not less than \$1,000,000 each occurrence and \$2,000,000 policy aggregate covering the professional services performed in connection with the project and continuing in force by renewal or extended reporting provision for not less than three years after completion of the Services.

**Heartland Alliance  
Heartland Alliance International  
Heartland Alliance Health  
Heartland Housing  
Heartland Human Care Services**

**Appendix 1 – CERTIFICATION OF INDEPENDENT PRICE DETERMINATION**

The vendor certifies that—

(a) (1) The prices in this offer have been arrived at independently, without, for the purpose of restricting competition, any consultation, communication, or agreement with any other vendor, including but not limited to subsidiaries or other entities in which vendor has any ownership or other interests, or any competitor relating to (i) those prices, (ii) the intention to submit an offer, or (iii) the methods or factors used to calculate the prices offered;

(2) The prices in this offer have not been and will not be knowingly disclosed by the vendor, directly or indirectly, to any other vendor, including but not limited to subsidiaries or other entities in which vendor has any ownership or other interests, or any competitor before bid opening (in the case of a sealed bid solicitation) or contract award (in the case of a negotiated or competitive solicitation) unless otherwise required by law; and

(3) No attempt has been made or will be made by the vendor to induce any other concern or individual to submit or not to submit an offer for the purpose of restricting competition or influencing the competitive environment.

(b) Each signature on the offer is considered to be a certification by the signatory that the signatory—

(1) Is the person in the vendor's organization responsible for determining the prices being offered in this bid or proposal, and that the signatory has not participated and will not participate in any action contrary to subparagraphs (a)(1) through (a)(3) above; or

(2) (i) Has been authorized, in writing, to act as agent for the principals of the vendor in certifying that those principals have not participated, and will not participate in any action contrary to subparagraphs (a)(1) through (a)(3) above;

(ii) As an authorized agent, does certify that the principals of the vendor have not participated, and will not participate, in any action contrary to subparagraphs (a)(1) through (a)(3) above; and

(iii) As an agent, has not personally participated, and will not participate, in any action contrary to subparagraphs (a)(1) through (a)(3) above.

(c) Vendor understands and agrees that –

(1) violation of this certification will result in immediate disqualification from this solicitation without recourse and may result in disqualification from future solicitations; and

(2) discovery of any violation after award to the vendor will result in the termination of the award for default.

CERTIFIED BY:

RFQ No. 5501.2019.3

Name of Vendor Organization:

\_\_\_\_\_

Signature Authorized Official:

\_\_\_\_\_

Date: \_\_\_\_\_

Title: \_\_\_\_\_

Printed Name: \_\_\_\_\_

**Appendix 2 – CERTIFICATION REGARDING DEBARMENT, SUSPENSION, PROPOSED DEBARMENT, AND OTHER RESPONSIBILITY MATTERS**

(a)(1) The Offeror certifies, to the best of its knowledge and belief, that—

(i) The Offeror and/or any of its Principals—

(A) Are [ ] are not [ ] presently debarred, suspended, proposed for debarment, or declared ineligible for the award of contracts by any Federal agency;

(B) Have [ ] have not [ ], within the three-year period preceding this offer, been convicted of or had a civil judgment rendered against them for: commission of fraud or a criminal offense in connection with obtaining, attempting to obtain, or performing a public (Federal, state, or local) contract or subcontract; violation of Federal or state antitrust statutes relating to the submission of offers; or commission of embezzlement, theft, forgery, bribery, falsification or destruction of records, making false statements, tax evasion, or receiving stolen property; [This language stayed indefinitely. Please use paragraph (a)(1)(i)(D) below.]

(C) Are [ ] are not [ ] presently indicted for, or otherwise criminally or civilly charged by a governmental entity with, commission of any of the offenses enumerated in paragraph (a)(1)(i)(B) of this provision; and [This language stayed indefinitely. Please use paragraph (a)(1)(i)(E) below.]

(D) Have [ ] have not [ ], within a three-year period preceding this offer, been convicted of or had a civil judgment rendered against them for: commission of fraud or a criminal offense in connection with obtaining, attempting to obtain, or performing a public (Federal, state, or local) contract or subcontract; violation of Federal or state antitrust statutes relating to the submission of offers; or commission of embezzlement, theft, forgery, bribery, falsification or destruction of records, making false statements, tax evasion, or receiving stolen property; and

(E) Are [ ] are not [ ] presently indicted for, or otherwise criminally or civilly charged by a governmental entity with, commission of any of the offenses enumerated in subdivision (a)(1)(i)(D) of this provision.

(ii)(A) [This paragraph (a)(1)(ii) is stayed indefinitely.] The offeror, aside from the offenses enumerated in paragraphs (a)(1)(i)(A), (B), and c) of this provision, has [ ] has not [ ] within the past three years, relative to tax, labor and employment, environmental, antitrust, or consumer protection laws—

(1) Been convicted of a Federal or State felony (or has any Federal or State felony indictments currently pending against them); or

(2) Had a Federal court judgment in a civil case brought by the United States rendered against them; or

(3) Had an adverse decision by a Federal administrative law judge, board, or commission indicating a willful violation of law.

(B) If the offeror has responded affirmatively, the offeror shall provide additional information if

requested by the Contracting Officer; and (iii) The Offeror has [ ] has not [ ], within a three-year period preceding this offer, had one or more contracts terminated for default by any Federal agency.

(2) "Principals," for the purposes of this certification, means officers; directors; owners; partners; and, persons having primary management or supervisory responsibilities within a business entity (e.g., general manager; plant manager; head of a subsidiary, division, or business segment, and similar positions).

This Certification Concerns a Matter Within the Jurisdiction of an Agency of the United States and the Making of a False, Fictitious, or Fraudulent Certification May Render the Maker Subject to Prosecution Under Section 1001, Title 18, United States Code.

(b) The Offeror shall provide immediate written notice to the Contracting Officer if, at any time prior to contract award, the Offeror learns that its certification was erroneous when submitted or has become erroneous by reason of changed circumstances.

(c) A certification that any of the items in paragraph (a) of this provision exists will not necessarily result in withholding of an award under this solicitation. However, the certification will be considered in connection with a determination of the Offeror's responsibility. Failure of the Offeror to furnish a certification or provide such additional information as requested by the Contracting Officer may render the Offeror nonresponsible.

(d) Nothing contained in the foregoing shall be construed to require establishment of a system of records in order to render, in good faith, the certification required by paragraph (a) of this provision. The knowledge and information of an Offeror is not required to exceed that which is normally possessed by a prudent person in the ordinary course of business dealings.

(e) The certification in paragraph (a) of this provision is a material representation of fact upon which reliance was placed when making award. If it is later determined that the Offeror knowingly rendered an erroneous certification, in addition to other remedies available to the Government, the Contracting Officer may terminate the contract resulting from this solicitation for default.

CERTIFIED BY:

RFQ No. 5501.2019.3

Name of Vendor Organization:

Signature Authorized Official:

\_\_\_\_\_

\_\_\_\_\_

Date: \_\_\_\_\_

Title: \_\_\_\_\_

Printed Name: \_\_\_\_\_

## Appendix 3 - HEARTLAND ALLIANCE TERMS AND CONDITIONS

### Standard Terms and Conditions

**1. Acceptance & Applicability:** These terms and conditions, which are hyperlinked from or referenced in the Request for Proposal ("RFP") or Request for Quote ("RFQ") or otherwise provided to the supplier ("Vendor") of goods ("Goods") and/or services ("Services") collectively constitutes a binding agreement ("Agreement") between the Vendor and the Heartland entity ("Heartland") identified in the RFP/RFQ. This Agreement may be accepted only in accordance with all terms and conditions herein without modification, addition, deletion or alteration.

**2. Assignment:** Vendor may not assign this Agreement or any benefits or rights arising therefrom without the prior written consent of Heartland, and, unless otherwise agreed in writing, the rights of any assignee shall be subject to all set-offs, counterclaim.

**3. Proprietary Information & Confidentiality:** Vendor shall consider all data, documentation, drawings, specifications software and other information furnished by Heartland to be confidential and proprietary and shall not disclose any such information or use such information itself for any purpose other than that for which it was intended in completing the Contract, unless Vendor obtains written permission from Heartland to do so.

**4. Terms of Payment:** Subject to any superseding terms on the face hereof, Vendor shall invoice the Heartland entity awarding the RFP/RFQ. All invoices should be addressed to: Accounts Payable Division, 208 S. LaSalle St., Suite 1300, Chicago, IL 60604, and be paid upon completion/acceptance of the required Goods/Services. Vendor shall be paid not later than thirty (30) days after Heartland's receipt of an acceptable invoice or Heartland's receipt of the completed Goods/Services, together with any required documents. Drafts will not be honored.

**5. Identification:** All shipping containers, shipped documents and invoices must be labeled with the purchase order number and "Shipped to" information without exception. Every shipment must be accompanied by a legible packing list or tally containing complete order information.

**6. Delivery:** No delivery should take place outside the specified destination. If delivery cannot be made within the stated date and time, vendor must contact the originator that is receiving on the behalf of Heartland. Deliveries made to Heartland and its affiliates must have a signature.

**7. Special Payment:** No C.O.D. shipments will be accepted. Vendor is responsible for the cost of shipment to Heartland.

**8. Compliance with Law:** Vendor's performance of Services and all Goods to be delivered hereunder shall be in accordance with any and all applicable executive orders, Federal, State, municipal, and local laws and ordinances, and rules, orders, requirements and regulations.

**9. Title and Risk of Loss:** Title to and risk of loss of, each Goods and/or Services to be delivered hereunder shall, unless otherwise provided herein, pass from Vendor to Heartland upon acceptance of by Heartland.

**10. Inspection:** (a) Vendor shall work within professional standards and limitations specified on work statements, drawings and specifications covering the work and shall make such

inspections as are deemed necessary to ensure Vendor compliance, unless deviation there from is authorized in writing by Heartland. (b) All shipments shall be subject to final inspection by Heartland after receipt by Heartland at destination. If Goods supplied or Services performed by Vendor are found to be defective, Vendor shall be given the opportunity to correct any deficiencies within a reasonable period of time. If correction of such work is impracticable, Vendor shall bear all risk after notice of rejection and shall, if so requested by Heartland and at its own expense, promptly make all necessary replacements. Vendor shall provide immediate notice to Heartland of any potential failure on the part of its suppliers to provide supplies/services required hereunder. Vendor is responsible for any deficiency on the part of its suppliers. **VENDOR SHALL BE RESPONSIBLE FOR ANY COSTS OF REPROCUREMENT AS MAY BE NECESSARY FOR HEARTLAND TO SECURE THE SUPPLIES/SERVICES AS A RESULT OF VENDOR'S INABILITY TO PERFORM THAT EXCEED THE AGREED UPON PRICE HEREIN.** (d) Final inspection and acceptance by Heartland shall be conclusive except for latent defects, fraud, or for any rights provided by any product warranty.

**11. Force Majeure:** The Vendor shall not be liable by reason of any failure in performance of this Agreement in accordance with its terms if such failure arises out of causes beyond the control and without the fault or negligence of Vendor. Such cases may include, but are not restricted to, acts of God, acts of government or municipal or other authorities, fires, floods, epidemics, quarantines, strikes, and labor disputes. Such causes do not include deficiencies on the part of its suppliers.

**12. General Warranty:** Vendor warrants all Goods/Services to be free from all materials defects and expressly represents that all such required supplies/services are capable of performing the function service for which they were intended. Vendor agrees to pass on all manufacturers' warranties to Heartland.

**13. Liens:** Vendor agrees to deliver the Goods/Services which are the subject-matter of this Agreement to Heartland free and clear of all liens, claims, and encumbrances.

**14. Stop Work and Termination:** (a) Heartland shall have the right to direct Vendor to stop work at any time. Such direction must be in writing and shall be effective for a period of not more than 30 days after which time Vendor may continue work absent direction to do so or a notice of termination. (b) This Agreement may be terminated upon default of either party in meeting its obligations hereunder. (c) This Agreement may be terminated for convenience, without fault of either party, by Heartland with advance written notice to Vendor. Vendor shall be paid for Goods supplied and accepted by Heartland, and Services completed and shall be reimbursed all actual costs for work in process incurred at time of termination notification inclusive of any associated administrative costs, restocking charges, vendor cancellation charges and settlement costs. Under no circumstances shall Vendor receive more than the original value of this Agreement. (d) This Agreement may be terminated for constructive default in the event that the Heartland has reasonable cause to believe that the Vendor will not be able to perform in accordance with the terms and conditions of the Agreement. Vendor shall be given a reasonable opportunity to respond to a notice of constructive default termination. In the event of failure of the Vendor to deliver/complete any part of this Agreement, then Heartland shall, at its sole discretion, have the right to accept any delivered/completed part and unilaterally reduce the agreed upon price accordingly. (e) Heartland acceptance of partial deliveries shall not constitute a waiver of any of the Vendor's remaining obligations hereunder. (f) The preceding paragraph (e) shall not limit any legal rights of either party to cancel this Agreement by reason of any default, and Heartland further reserves the right to cancel this Agreement without further liability for articles not accepted by Heartland in the event Vendor commits an act of bankruptcy, files or has filed against the petition of bankruptcy or insolvency or suffers any receivership or other similar petition to be

filed for or against it.

**15. Independent Relationship:** Nothing in this Agreement shall be construed as creating anything other than an independent Contractor relationship between Heartland and the Vendor.

**16. Work Product Presumptive Heartland Property:** All writings, books, articles, computer programs, databases, source and object codes, and other material of any nature whatsoever, including trademarks, trade names, and logos, that is subject to copyright protection and reduced to tangible form in whole or in part by Vendor in the course of Vendor's service to Heartland shall be considered a work made for hire, or otherwise Heartland property. During this Agreement and thereafter, Vendor agrees to take all actions and execute any documents that Heartland may consider necessary to obtain or maintain copyrights, whether during the application for copyright or during the conduct of an interference, infringement, litigation, or other matter (Heartland shall pay all related expenses). Vendor shall identify all materials in which Vendor intends to exempt from this provision prior to the use or development of such materials.

**17. Rights in Data:** The Vendor understands and agrees that Heartland may itself and permit others, including government agencies of the United States and other foreign governments, to reproduce through but not limited to the publication, broadcast, translation, creation of other versions, quotations there from, any provided publications and materials, and otherwise utilize this work and material based on this work. During the performance of this Agreement and thereafter, Vendor agrees to take all actions and execute any documents that Heartland may consider necessary to obtain or maintain copyrights, whether during the application for copyright or during the conduct of an interference, infringement, litigation, or other matter (all related expenses to be borne by Heartland). The Vendor shall identify all materials it intends to exempt from this provision prior to the use or development of such materials. The Vendor shall defend, indemnify, and hold harmless Heartland against all claims, suits, costs, damages, and expenses that Heartland may sustain by reason of any scandalous, libelous, or unlawful matter contained or alleged to be contained in the work, or any infringement or violation by the work of any copyright or property right; and until such claim or suit has been settled or withdrawn, Heartland may withhold any sums due the Vendor under this Agreement. Vendor agrees to specifically identify to Heartland any and all computer software licenses ("including shrink-wrap") that may be conveyed to Heartland. Vendor agrees that any and all computer software developed in the performance of this Agreement shall, unless otherwise agreed, become and remain the property of Heartland.

**18. Indemnity:** Vendor shall defend, indemnify, and hold harmless Heartland, its directors, officers, and employees harmless, against all suits, costs, damages, and expenses that Heartland may sustain by reason of Vendor's negligent or unlawful actions resulting from Vendor's performance under this Agreement, and Vendor shall hold Heartland, its directors, officers, and employees harmless from all liability and litigation expenses based upon alleged infringement of any patent except for the specific designs or specifications of Heartland.

**19. Liquidated Damages:** If the Vendor fails to deliver the supplies or perform the services within the time specified in this Agreement, Heartland may require that Vendor pay, in place of actual damages, liquidated damages in the amount of one percent (1%) of the agreement value for each day of delay. If Heartland terminates this agreement in whole or in part for default, as provided under Section 14 above, Vendor is liable for liquidated damages accruing until such time that Heartland reasonably obtains delivery or performance from another vendor. These liquidated damages shall be in addition to any excess costs for re-purchase. Vendor will not be charged with liquidated damages when delay of delivery or performance is beyond the control and without the fault or negligence of the Vendor.

**20. Warranty:** For a minimum of one (1) year after delivery to Heartland, Vendor warrants that the goods furnished hereunder shall conform to the requirements and specifications of this Agreement and shall be of good workmanship and quality, free of all defects and fit for the purpose for which they are intended. Disclaimers of express or implied warranties and limitations of liability from or in connection with Vendor's products ordered hereby will be of no effect unless assented to in writing by Heartland.

**21. Assignment:** Vendor cannot assign or subcontract any part of this Agreement without the prior written approval of Heartland.

**22. Non-Waiver:** Heartland's failure to insist upon strict performance of the terms and conditions hereof shall not be construed as a waiver of the right to rely thereon in the future.

**23. Drug Trafficking:** Heartland reserves the right to terminate this Agreement and to demand a refund or take other appropriate measures if the Vendor is found to have been convicted of a narcotics offense or to have been engaged in drug trafficking as defined in 22 CFR Part 140.

**24. Terrorism E.O. 13224:** Vendor agrees and certifies to take all necessary actions to comply with Executive Order No. 13224 on Terrorist Financing; blocking and prohibiting transactions with persons who commit, threaten to commit, or support terrorism. (E.O.13224 text available at: <http://www.whitehouse.gov/news/releases/2001/09/20010924-1.html> Note: Vendor is required to obtain the updated lists at the time of procurement of goods or services. The updated lists are available at: <http://treasury.gov/offices/enforcement/ofac/sanctions/terrorism.htm> and <http://www.un.org/Docs/sc/committees/1267>.)

**25. Computer Software Licenses:** Vendor agrees to specifically identify to Heartland any and all computer software licenses ("including shrinkwrap") as may be conveyed to Heartland. The Vendor agrees that any and all computer software developed in the performance of this Agreement shall, unless otherwise agreed, become and remain the property of Heartland.

**26. Vendor Terms and Conditions:** The terms and conditions of this Agreement shall supersede any other terms and conditions except those expressly accepted by Heartland in writing.

**27. Gratuities:** This Agreement may be terminated for cause in accordance with Section 14 above should it be determined by Heartland that Vendor offered or gave a gratuity (e.g. entertainment, gift, services or money) to any Heartland employee or other persons responsible for or connected to those responsible for the decision to award this Agreement or the acceptance of performance under this Agreement and that gratuity was intended to obtain this award or favorable treatment.

**28. Independent Price Determination:** (a) Vendor certifies that— (1) The prices in this Agreement have been arrived at independently, without, for the purpose of restricting competition, any consultation, communication, or agreement with any other offeror, including but not limited to subsidiaries or other entities in which Vendor has any ownership or other interests, or any competitor relating to (i) those prices, (ii) the intention to submit an offer, or (iii) the methods or factors used to calculate the prices offered; (2) The prices in this Agreement were not knowingly disclosed by the Vendor, directly or indirectly, to any other offeror, including but not limited to subsidiaries or other entities in which Vendor has any ownership or other interests, or any competitor before bid opening (in the case of a sealed



bid solicitation) or contract award (in the case of a negotiated or competitive solicitation) unless otherwise required by law; and (3) No attempt was made by the Vendor to induce any other business or individual to submit or not to submit an offer for the purpose of restricting competition or influencing the competitive environment. Vendor understands and agrees that violation of this certification will result in the termination of this Agreement for default as well as exclusion from future solicitations.

**29. Eligibility Rules for Goods and Services:** Vendors shall not procure any goods or services from firms or individuals whose name appears on the "Lists of Parties Excluded from Federal Procurement and Nonprocurement Programs."

**30. Ocean Shipment of Goods:** Applicable for awards for \$100,000 or more and when goods purchased under this award are transported to cooperating countries on ocean vessels whether or not award funds are used for the transportation. Vendor must ensure transport on a US flag commercial vessels. When U.S. flag vessels are not available, or their use would result in a significant delay, the vendor must contact Heartland Program Director before proceeding.

**31. Air Transportation:** In accordance with the standard provision entitled International Air Transportation, any international travel requires prior written approval from the Heartland Program Director.

**32. Authorized Geographic Code:** Vendor shall comply with the Geographic Code specified by the U.S. Government prime contract with Heartland, if any.

**33. Excusable Delays:** The Vendor shall be liable for default unless nonperformance is caused by an occurrence beyond the reasonable control of the Vendor and without its fault or negligence. The Vendor shall notify Heartland in writing as soon as it is reasonably possible after the commencement of any excusable delay.

**34. Export Control:** Vendor shall comply in all respects with all applicable local, state, and federal laws and regulations, as well as all U.S. statutes, regulations, and administrative requirements regarding relationships with non-U.S. governmental and quasi-governmental entities including but not limited to the export control regulations of the Department of State and the International Traffic in Arms Regulations ("ITAR"), the Department of Commerce and the Export Administration Act ("EAA"), the anti-boycott and embargo regulations and guidelines issued under the EAA, and the regulations of the U.S. Department of the Treasury, Office of Foreign Assets Control.

**35. Foreign Corrupt Practices Act:** The anti-bribery provisions of the Foreign Corrupt Practices Act of 1977 ("FCPA"), 15 U.S.C. §§ 78dd1", et seq., makes it unlawful for U.S. companies, as well as their officers, directors, employees, and agents, to corruptly offer or make a corrupt payment of money or anything of value to a foreign official for the purpose of obtaining or retaining business. Vendor acknowledges and understands that he/she must comply fully with the anti-bribery provisions of the FCPA. Specifically, Vendor understands and agrees that it shall be unlawful for the Vendor to pay, offer, promise to pay (or authorize to pay or offer) money or anything of value to a foreign official in order to assist Heartland in obtaining or retaining business for or with, or directing business to, Heartland. A "foreign official" means any officer or employee of a foreign government, a public international organization, or any department or agency thereof, or any person acting in an official capacity.

**36. Environment:** Vendor must operate in a manner that complies with national and local environmental laws, regulations and standards including, but not limited to, laws related to air

emissions, waste management, recycling, water discharge, toxic substances and hazardous waste disposal. Vendor agrees to comply with all applicable standards, orders or regulations issued pursuant to the Clean Air Act ( 42 U.S.C. 7401- 7671q) and the Federal Water Pollution Control Act as amended ( 33 U.S.C. 1251- 1387). Violations must be reported to the Federal awarding agency and the Regional Office of the Environmental Protection Agency (EPA).

**37. Rights to Inventions:** If the Vendor has been contracted for the assignment or performance of experimental, developmental, or research work under a Federal funding agreement, the Vendor must comply with the requirements of 37 CFR Part 401, "Rights to Inventions Made by Nonprofit Organizations and Small Business Firms Under Government Grants, Contracts and Cooperative Agreements," and any implementing regulations issued by the awarding agency.